

1 2 3 4 5 6

A

A

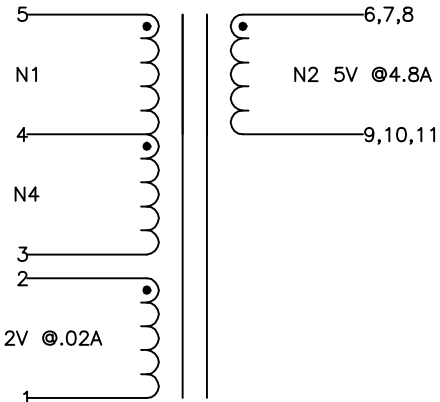
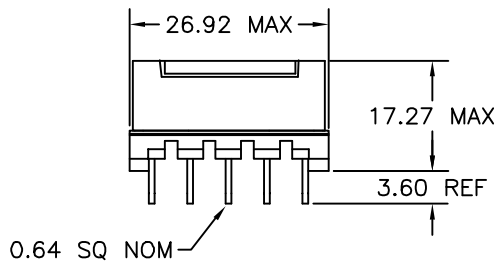

B

B

C

C

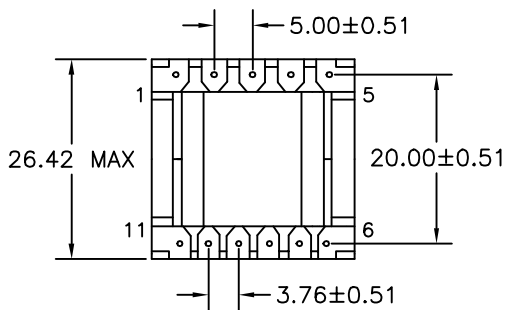

NOTE:
POLARITY SHOWN IS FOR THE
TRANSFORMER. FOR CORRECT
FLYBACK OPERATION CONNECT
B+ TO PIN 3.

D

D

E

E

ELECTRICAL SPECIFICATIONS

L @ 1kHz 10mA - (5-3) 1.10mH ±10%
 LL @ 100kHz 10mA - (5-3) 12.8µH TYP, TOL TBD
 (WITH 1,2,6-11 SHORTED)
 TURNS RATIO - ±3%
 N1/N4:N2 - 1:0.045
 N1/N4:N3 - 1:0.106
 DCR - OHMS TYP, TOL TBD
 N1/N4 - 0.897
 N2 - 0.009
 N3 - 0.098
 HIPOT - 4000VAC 1SEC
 N1,N3,N4 TO N2

NOTE:
MEETS CONSTRUCTION FOR:
UL 1310, 1950, 1411
EN60950

H

H

REVISION		DATE	MARKINGS	LOCATION
O	PRELIMINARY	05/13/03	CRAMER DATE CODE CVP 53-003	PIN RAIL SIDE OF CORE
A	RELEASED	05/19/03	DESCRIPTION 5V 4.8A VIPER 53 FLYBACK XFMR	TOLERANCE UNLESS OTHERWISE SPECIFIED 2 PLACE DECIMALS ±.010 3 PLACE DECIMALS ±.005 FRACTIONS ±1/64 ANGLES ±1/2°
B	PIN SIZE WAS 0.031 DIA NOM	05/22/03	CUSTOMER	PROPRIETARY INFORMATION PROPERTY OF CRAMER COIL & TRANSFORMER CO. DUPLICATION AND/OR DISTRIBUTION BY PERMISSION ONLY
C	UPDATED PIN TO PIN & ROW TO ROW DIMENSIONS	07/01/03		
D	INSERTED TOOLED BOBBIN	08/29/05		
			G:\DATA\SPECS\ENG\CVP\53-003	CUSTOMER PART NUMBER
			DR. MEC	DATE 05/13/03
			APPD. JDB	DATE 05/19/03
				CRAMER PART NUMBER CVP 53-003
				REV D

J

J

1 2 3 4 5 6